

Taping Specification for Radial film capacitors

Taping Information

RADIAL DIPPED FILM CAPACITORS (dimension in mm)

pitch = 5.0mm(kinked leads)

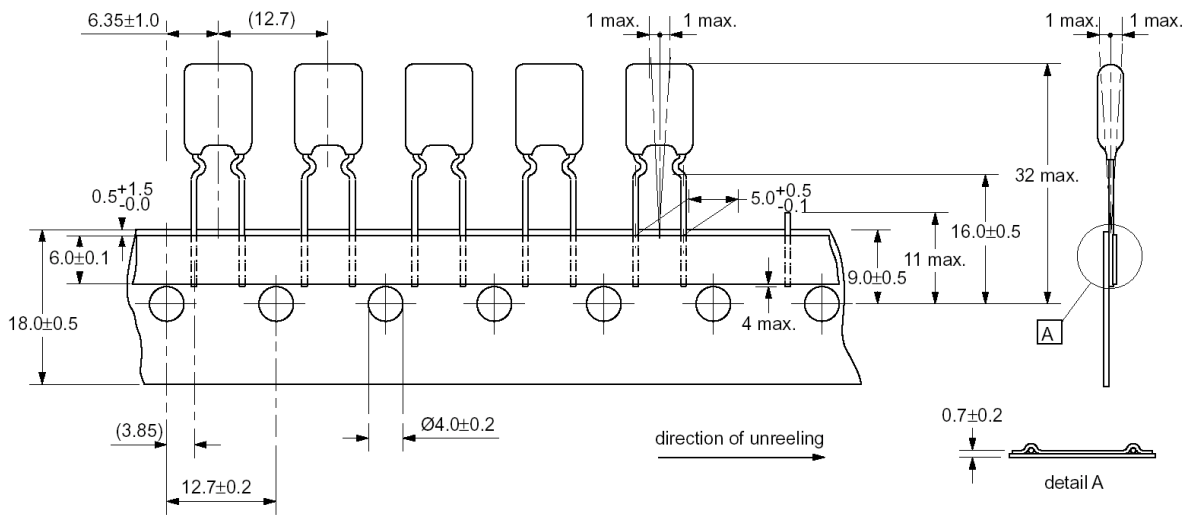

pitch = 5.0mm(bent back leads)

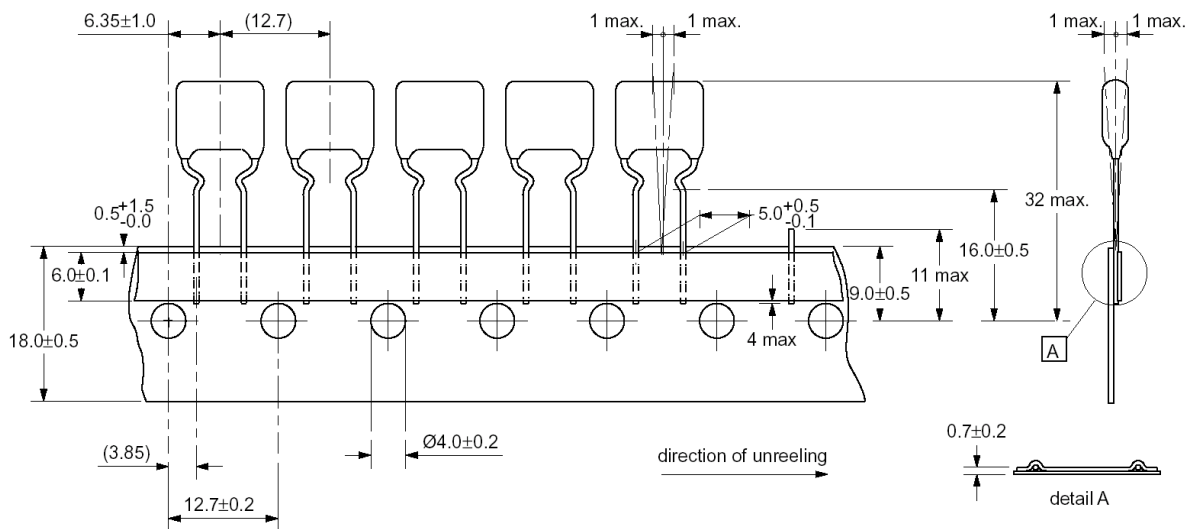

Taping Specification for Radial film capacitors

Taping Information

pitch = 10.0mm(kinked leads)

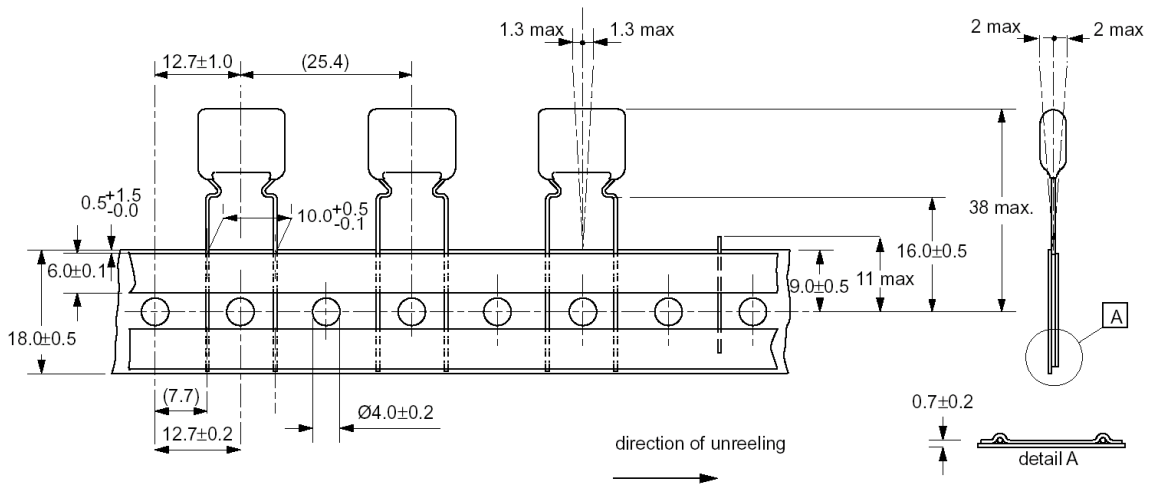

pitch = 15.0mm(kinked leads)

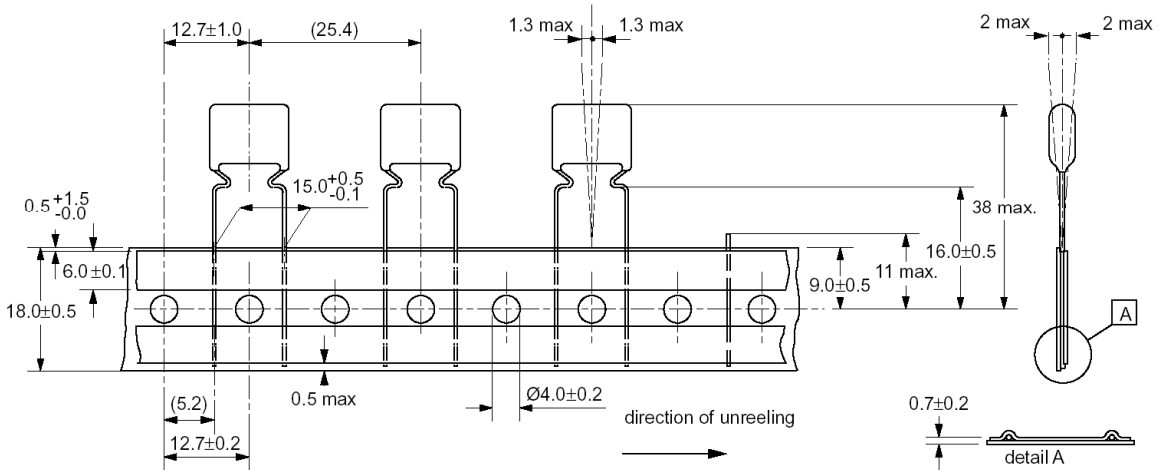

Taping Specification for Radial film capacitors

Taping Information

pitch = 22.5mm(kinked leads)

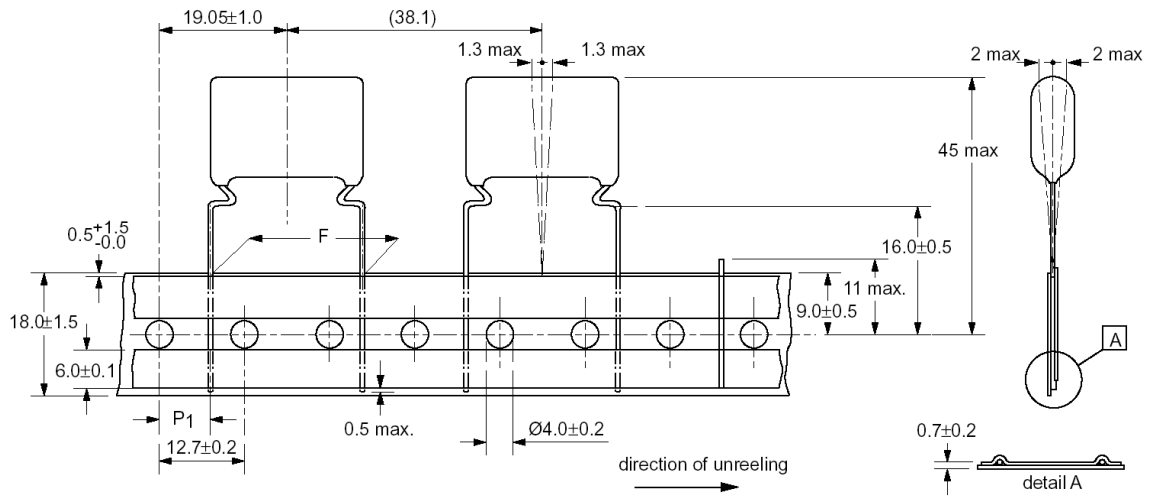

original pitch = 15.0mm (bent back pitch = 7.5mm)

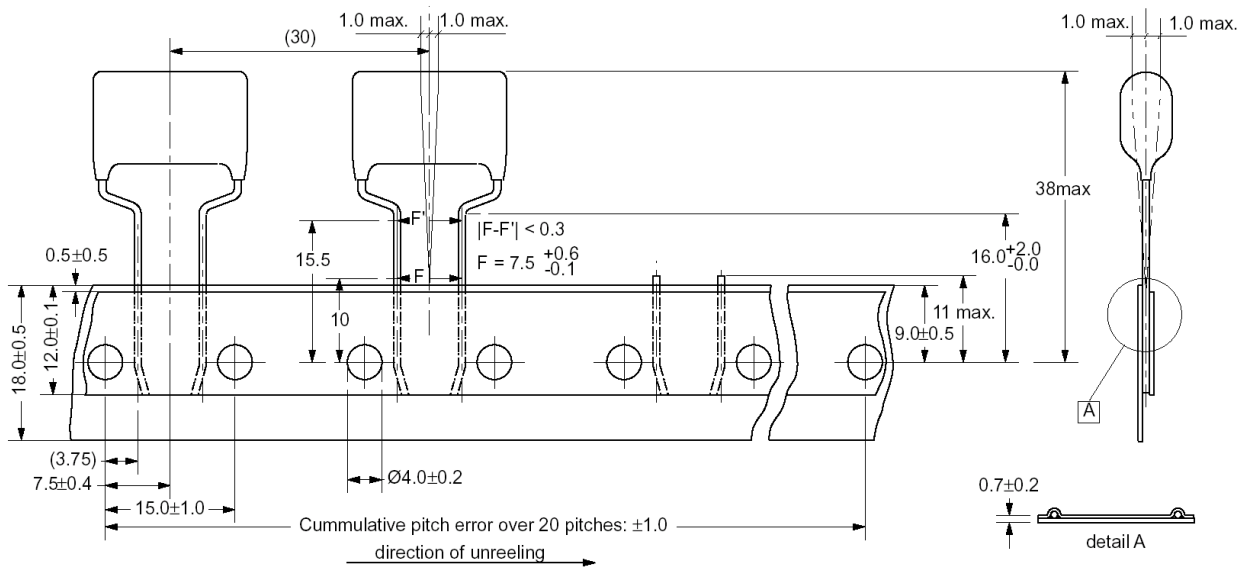

Taping Specification for Radial film capacitors

Taping Information

Outlines of reel and ammo pack (dimension in mm)

pitch = 5.0mm

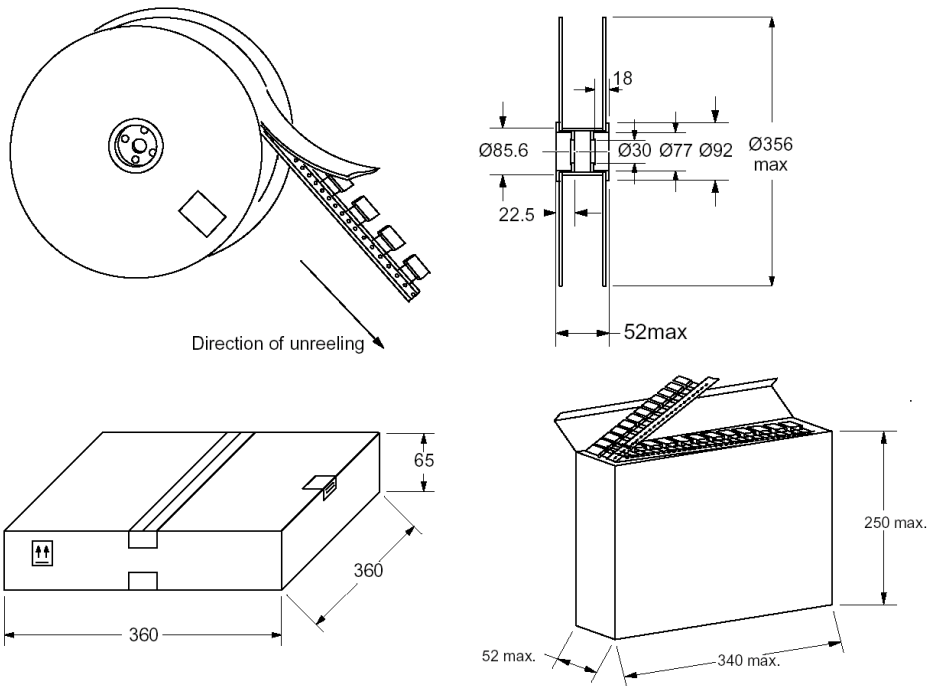

pitch = 10.0mm, 15.0mm, 22.5mm

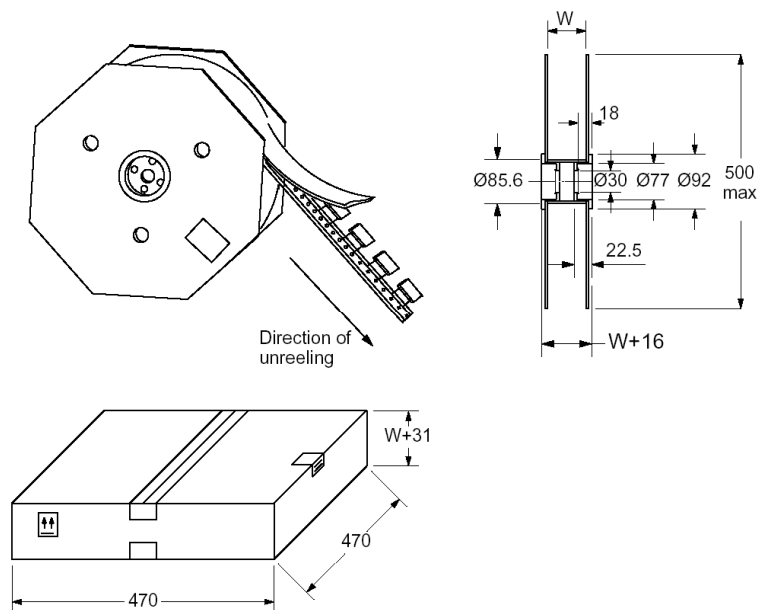

Taping Specification for Radial film capacitors

Taping Information

Ammopacking box dimension

Hole to Hole	I_{max} (mm)	Box dimension (A x B x C mm)
12.7 mm	12.5	310 x 296 x 55
	18.0	290 x 380 x 55
	26.0	385 x 370 x 55
	31.0	420 x 340 x 55
15.0 mm	All type	300 x 314 x 55

W as a function of product dimensions (I_{max} and b_{max})

$I_{max} = 12.5$ or 18.0 mm		$I_{max} = 26$ or 31 mm	
b_{max} (mm)	W ± 2 (mm)	b_{max} (mm)	W ± 2 (mm)
4.5	68	5.5 – 9.5	68
5.0	68		
5.5	68		
6.0	68		
6.5	68		
7.0	68	10.0 – 12.0	73
7.5	68		
8.0	68		
8.5	68	12.5 – 14.0	78
9.0	68		
10.0	68		

Cumulative pitch error : 1.0mm/20 pitches.

The maximum number of empty positions per reel shall not exceed 0.5% of total number of components per reel, but no more than 2 consecutive position may be vacant.

Taping specification – Hole to hole 12.7 and 15.0mm

Name	Specification		Application
Standard taping	Reel	5/7.5/10/15/20/22.5/27.5mm pitch	365/369
	Ammo		

Taping Specification for Radial film capacitors

Taping Information

RADIAL Potted FILM CAPACITORS (dimension in mm)

Capacitor with pitch = 10mm

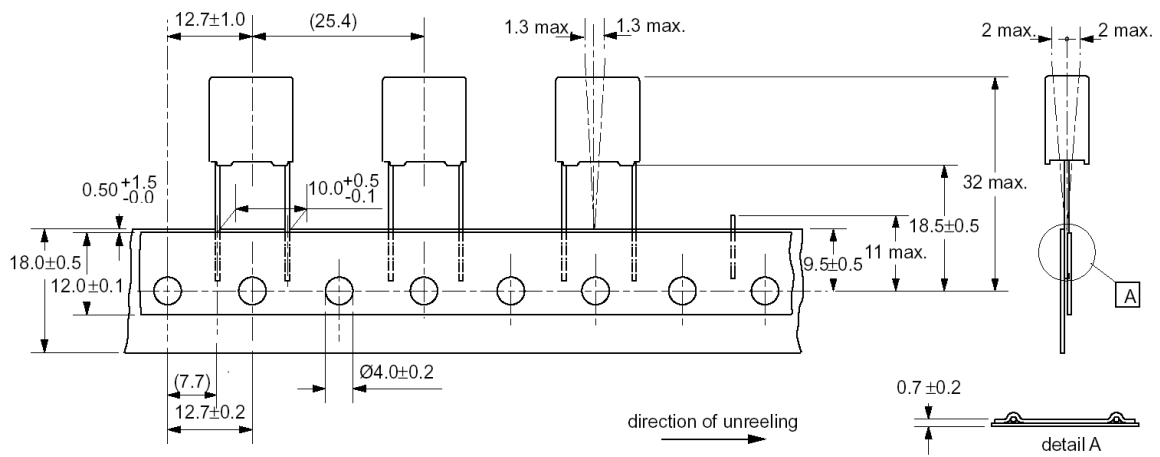

Capacitor with pitch = 15mm

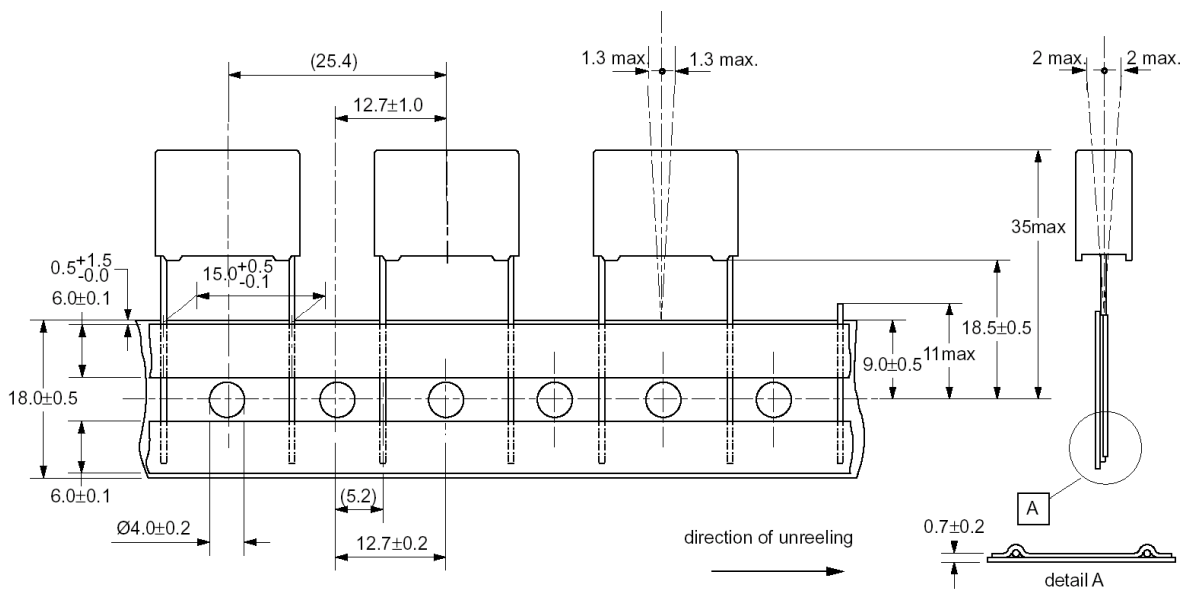

Taping Specification for Radial film capacitors

Taping Information

Capacitor with pitch = 22.5 and 27.5mm

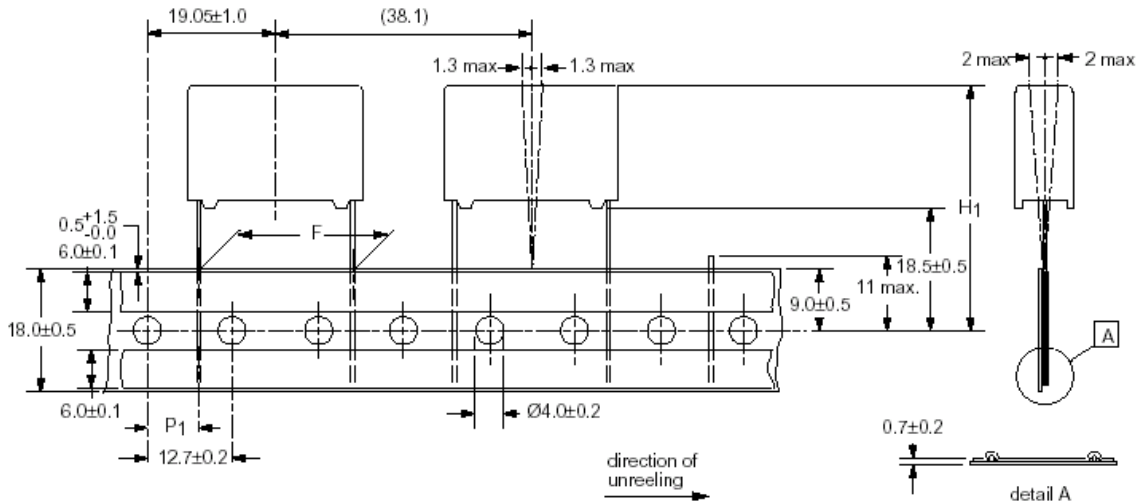

Original pitch = 15mm (bent back pitch = 7.5mm)

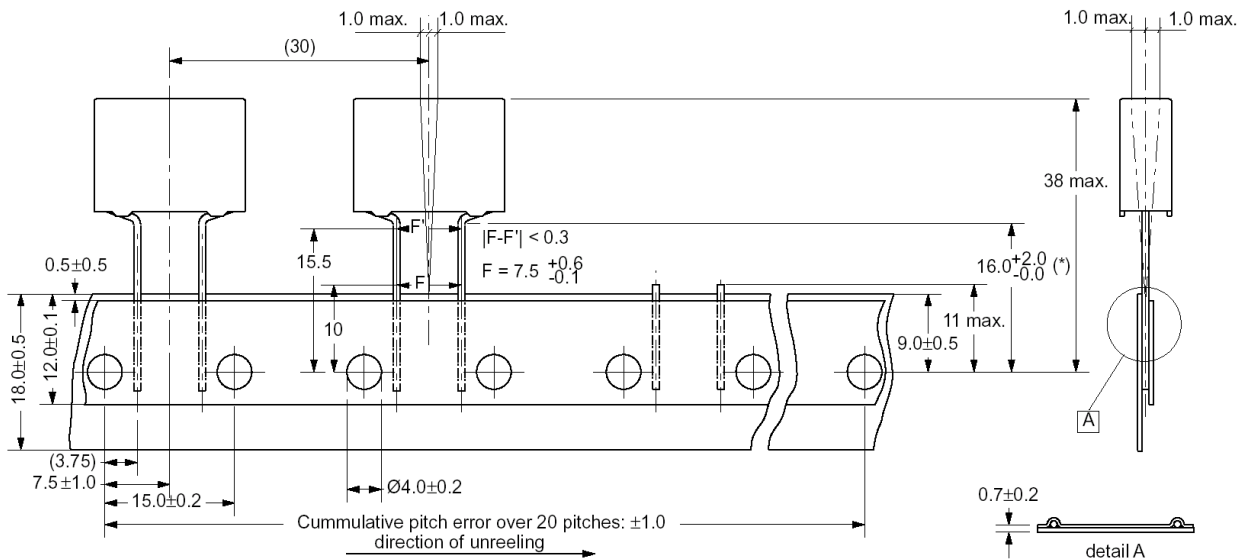

Taping Specification for Radial film capacitors

Taping Information

SYMBOL	PARAMETER	VALUE		Tol.	UNIT
F1	Lead to lead distance	22.5	27.5	+0.5/-0.1	mm
H1	Component height from tape center	40 max	48 max	-	mm
P1	Feed hole to lead center	(7.8)	(5.3)		mm

DESCRIPTION	VALUE
Pull-off force of the component	≥ 5N
Pell-off force of the adhesive tape	≥ 6N
Tearing force of tape	≥ 15N
STORAGE CONDITIONS	
Storage temperature	-25 to +40°C
Maximum relative humidity without condensation	81%

Outlines of reel and ammpack (dimensions in mm)

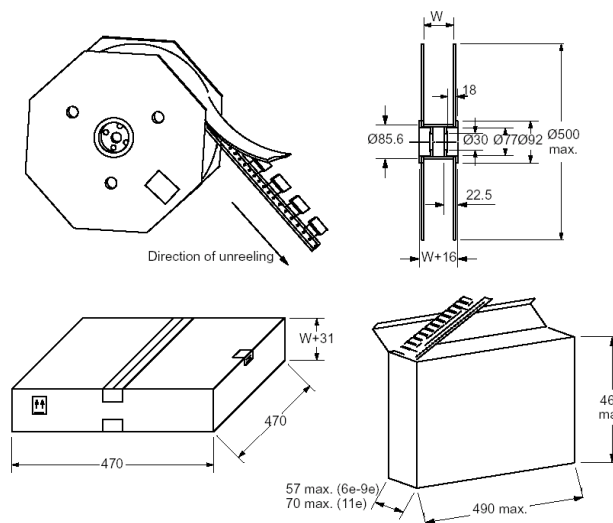

**Taping Specification for
Radial film capacitors**

Taping Information

Outlines of reel and ammpack (dimensions in mm)

$l_{max} = 12.5$ or 18.0 mm		$l_{max} = 26$ or 31 mm	
b_{max} (mm)	$W \pm 2$ mm	b_{max} (mm)	$W \pm 2$ mm
4.0	40	6.0	50
5.0	45	7.0	50
6.0	45	8.5	50
7.0	45	9.0	50
8.5	45	10.0	50
10.0	50	11.0	55
		13.0	55
		15.0	60
		18.0	60
		21.0	65

Cumulative pitch error : 1.0 mm/20 pitches.

The maximum number of empty positions per reel shall not exceed 0.5%(*) of the total number of components per reel, but no more than 2 consecutive positions may be vacant provided this gap is followed by 6 consecutive components.

* 5% for capacitors with b_{max} : 4.5, 5 or 6mm in ammpack.